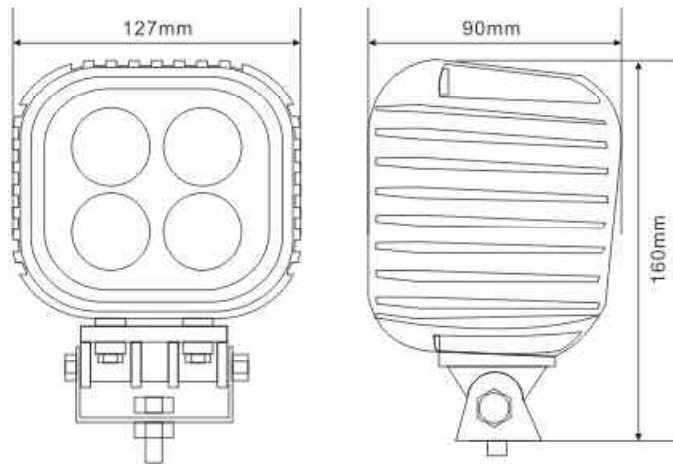

Technical Information Sheet**Part No. 0-420-73**

A powerful 4 x 10 watt 10-30 volt CREE LED Work lamp. Black powder coated die cast aluminium case, polycarbonate lens, supplied with stainless steel bracket. Protected to IP67. I 90 x w 127 x h 160mm. Approx Life: 50,000 hours.

**Technical Drawing (not to scale)****Specification**

Type	LED work lamp
Voltage	10-30 volt dc
LEDs	CREE 4 x 10W (6000K)
Light Output	3500Lumen Approx
Housing	Die cast aluminium
Bracket	Stainless steel
Lens	Polycarbonate PMMA
Degree of protection	IP67
Operating temperature	-40°C to +60°C
Weight	1.6KG
Dimensions	I 90 x w 127 x h 160mm

The information contained in this document is correct to the best of our knowledge at the time of printing. However, specifications may change at any time without notice.